

SAB



SAB

The functions of the Aston Seals SAB bi-directional rod wiper are:

- to prevent introduction of dust, dirt and foreign matter into the system; this is achieved by a special wiper lip which produces a very effective cleaning action, prevents the development of scores, protects the guiding parts and extends the service life of the axial moving rod seals.
- to retain residual oil film on the rod; the asymmetric lips are designed to differentiate the behaviour of the lips on the static and dynamic surfaces: the static lips are flexible and more sensitive to pressure fluctuations; the dynamic lip is shorter and stronger to concentrate load against the dynamic surface.

The material used to produce this wiper is a polyurethane compound that ensures excellent properties in case of dry run, an increased wear-resistance and an extended service life due to good resistance against ozone and radiation caused by weather conditions.

- Retaining residual oil film
- Extended service life
- Insensitive to structural deflections
- Excellent wear-resistance
- Space-saving construction
- No close tolerances are necessary
- Easy installation without expensive auxiliaries

MATERIAL



Type	Designation	Hardness
Polyurethane	SEALPUR 93	93 °ShA

FIELD OF APPLICATION



Fluids Hydraulic oils (mineral oil based)
For other fluids contact our technical department

SURFACE ROUGHNESS

Dynamic surface	Ra ≤ 0.3 µm	Rt ≤ 2.5 µm
Static surface	Ra ≤ 1.6 µm	Rt ≤ 6.3 µm

LEAD-IN CHAMFERS

d	Smin
less 100	5 mm
100÷200	7 mm
over 200	10 mm

To avoid damaging the sealing lips during installation, housing must have rounded chamfers. Sharp edges and burrs within the installation area of the seal must be removed.

The above data are maximum values, they may be maintained for short periods and can not be used at the same time simultaneously.

SAB

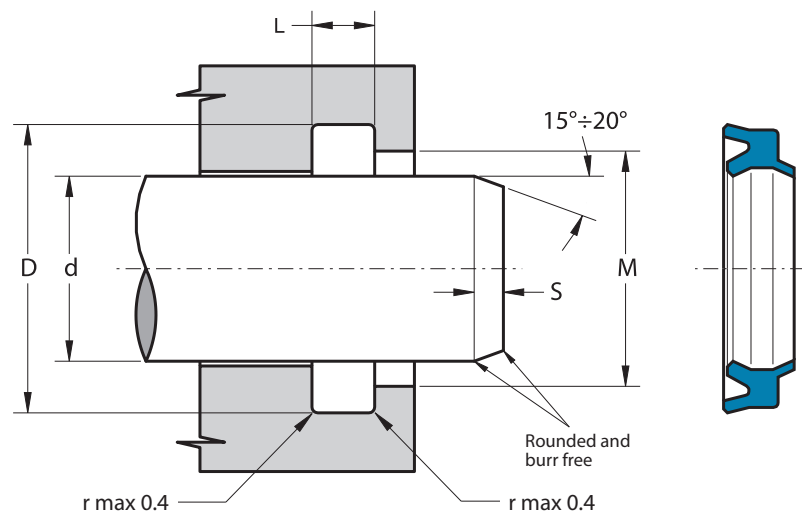

Part.	d ^{f7}	D ^{H10}	L ^{+0.2}	M ^{+0.2}
SAB 10/ISO	10	16.0	4.0	12.5
SAB 10 20 6	10	20.0	6.5	14.0*
SAB 12	12	18.6	3.8	15.0
SAB 12 26 6.6	12	26.0	7.0	15.0*
SAB 14	14	20.6	3.8	17.0
SAB 14/ISO	14	20.0	4.0	16.5
SAB 16/A	16	24.0	5.0	20.3
SAB 16/ISO	16	22.0	4.0	18.5
SAB 17	17	23.6	3.8	20.0
SAB 18	18	24.6	3.8	21.0
SAB 20	20	28.6	5.3	23.0
SAB 20/ISO	20	26.0	4.0	22.5
SAB 22	22	30.6	5.3	25.0
SAB 22/ISO	22	28.0	4.0	24.5
SAB 25	25	33.6	5.3	28.0
SAB 25/A	25	33.0	4.8	29.3
SAB 25/ISO	25	31.0	4.0	27.5
SAB 28	28	36.6	5.3	31.0
SAB 28/ISO	28	36.0	5.0	31.0
SAB 30	30	38.6	5.3	33.0
SAB 30/A	30	38.0	5.0	33.0
SAB 30/B	30	38.0	5.8	34.0
SAB 32	32	40.6	5.3	35.0
SAB 32/ISO	32	40.0	5.0	35.0

Part.	d ^{f7}	D ^{H10}	L ^{+0.2}	M ^{+0.2}
SAB 35	35	43.6	5.3	38.0
SAB 36	36	44.6	5.3	39.0
SAB 36/ISO	36	44.0	5.0	39.0
SAB 37	37	45.6	5.3	40.0
SAB 38	38	46.6	5.3	41.0
SAB 40	40	48.6	5.3	43.0
SAB 40/B	40	50.0	6.3	44.5
SAB 40/ISO	40	48.0	5.0	43.0
SAB 42	42	50.6	5.3	45.0
SAB 45	45	53.6	5.3	48.0
SAB 45/ISO	45	53.0	5.0	48.0
SAB 46/A	46	54.0	6.0	49.0
SAB 49/A	49	57.0	6.3	52.0
SAB 50	50	58.6	5.3	53.0
SAB 50/A	50	58.0	4.0	53.0
SAB 50/ISO	50	58.0	5.0	53.0
SAB 55	55	63.6	5.3	58.0
SAB 55/A	55	65.0	6.0	58.0
SAB 56/ISO	56	66.0	6.0	59.0
SAB 60	60	68.6	5.3	63.0
SAB 60/ISO	60	70.0	6.0	63.0
SAB 63	63	71.6	5.3	66.0
SAB 63/ISO	63	73.0	6.0	66.0
SAB 65	65	73.6	5.3	68.0

Part.	d ^{f7}	D ^{H10}	L ^{+0.2}	M ^{+0.2}
SAB 65/A	65	75.0	6.0	68.0
SAB 70	70	78.6	5.3	73.0
SAB 70/ISO	70	80.0	6.0	73.0
SAB 75	75	83.6	5.3	78.0
SAB 78/A	78	88.2	7.1	84.0
SAB 80	80	88.6	5.3	83.0
SAB 80/A	80	92.6	7.1	86.0
SAB 80/ISO	80	90.0	6.0	83.0
SAB 82/A	82	94.2	7.1	88.0
SAB 85	85	97.2	7.1	91.0
SAB 90	90	102.2	7.1	96.0
SAB 90/ISO	90	100.0	6.0	93.0
SAB 100	100	112.2	7.1	106.0
SAB 100/A	100	110.0	6.0	103.0
SAB 104	104	116.2	7.1	110.0
SAB 110	110	122.2	7.1	116.0
SAB 129	129	141.2	7.1	135.0
SAB 154	154	166.2	7.1	160.0
SAB 180	180	192.2	7.1	186.0

Inch sizes

SAB 3500	88.9	101.47	7.14	92.33
----------	------	--------	------	-------

* Open groove assembly