

### DESCRIPTION

Single acting rod seal for pneumatic cylinders

### MATERIAL

Type: Polyurethane  
Designation: SEALPUR 93  
Hardness: 93 °ShA

### MAIN FEATURES

It is a U-shaped single acting rod seal.

The asymmetric lips are designed to differentiate the behavior of the lips on the static and dynamic surfaces: the dynamic lip is flexible, more sensitive to pressure fluctuations and with a special rounded lip designed for pneumatic application to maintain lubricating film and minimize friction; the static lip is longer and stronger to concentrate load against the static surface.

The material used to produce this seal is a polyurethane compound, specifically developed for the production of pneumatic seals, that ensures excellent properties on wear-resistance, extended service life and low permanent deformation.

- Simple groove design
- Geometry of the sealing lips is designed to operate with air lubricated and dry
- Low friction at all usage pressure
- Easy installation without expensive auxiliaries
- Excellent wear-resistance
- Extended service life

### FIELD OF APPLICATION

Pressure	≤ 20 bar
Speed	≤ 1 m/s
Temperature	-35°C ÷ +80°C
Fluids	Air with or without lubrication, grease, mineral oils, non-aggressive gases, etc.

### SURFACE ROUGHNESS

Dynamic surface	Ra ≤ 0.25 μm	Rt ≤ 2.5 μm
Static surface	Ra ≤ 0.8 μm	Rt ≤ 6.3 μm

### LEAD-IN CHAMFERS

d	S <sub>MIN</sub>
•less 20	3 mm
20÷50	4 mm
51÷150	5 mm
•over 150	6 mm

- to avoid damaging the sealing lips during installation, housing must have rounded chamfers. Sharp edges and burrs within the installation area of the seal must be removed

Part.	d <sup>f7</sup>	D <sup>H10</sup>	L <sup>+0.5</sup>
GSP 3 14 4	3	14	4.5
GSP 4 14 4	4	14	4.5
GSP 5 9 2.5	5	9	3
GSP 5 14 4	5	14	4.5
GSP 6 14 4	6	14	4.5
GSP 6 10 3	6	10	3.5
GSP 7 14 4	7	14	4.5
GSP 8 14 2.55	8	14	3
GSP 8 14 4	8	14	4.5
GSP 8 16 2.55	8	16	3
GSP 10 16 2.55	10	16	3

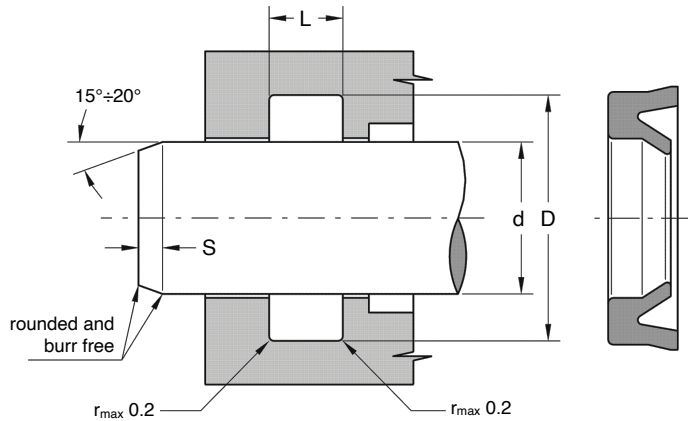

Part.	d f7	D H10	L +0.5
GSP 12 18 2.55	12	18	3
GSP 12 24 6	12	24	6,5
GSP 14 22 5.5	14	22	6
GSP 16 22 2.55	16	22	3
GSP 16 24 5.5	16	24	6
GSP 17 24 2.55	17	24	3
GSP 19 25 3.25	19	25	3.5
GSP 20 28 5.5	20	28	6
GSP 22 28 4.3	22	28	5
GSP 22 30 5.5	22	30	6
GSP 25 33 5.5	25	33	6
GSP 35 43 8	35	43	8.5
GSP 35 45 7.5	35	45	8
GSP 35 45 10	35	45	11
GSP 40 48 5.5	40	48	6
GSP 45 55 7	45	55	7.5
GSP 50 60 6.5	50	60	7
GSP 60 72 8.5	60	72	9.5
GSP 160 175 10	160	175	11